

|               |              |
|---------------|--------------|
| Spec. No.     |              |
| Doc. version: | 0            |
| Total pages:  | 19           |
| Date          | : 2003/05/10 |

# Product Specification

## 2.5" COLOR TFT-LCD MODULE

MODEL NAME: A025CN03

< ◆ > Preliminary Specification  
< > Final Specification

Note: The content of this specification is subject to change without prior notice.

© 2003 AU Optronics  
All Rights Reserved.

## Record of Revision

| Version | Revise Date | Page | Content            |
|---------|-------------|------|--------------------|
| 1       | 10/May/2003 |      | First draft issued |
|         |             |      |                    |
|         |             |      |                    |
|         |             |      |                    |
|         |             |      |                    |
|         |             |      |                    |
|         |             |      |                    |
|         |             |      |                    |
|         |             |      |                    |
|         |             |      |                    |
|         |             |      |                    |
|         |             |      |                    |
|         |             |      |                    |
|         |             |      |                    |
|         |             |      |                    |
|         |             |      |                    |
|         |             |      |                    |
|         |             |      |                    |
|         |             |      |                    |
|         |             |      |                    |
|         |             |      |                    |
|         |             |      |                    |
|         |             |      |                    |
|         |             |      |                    |
|         |             |      |                    |

Confidential

**Contents:**

|   |            |
|---|------------|
| <b>A. Physical specifications</b> .....   | <b>P3</b>  |
| <b>B. Electrical specifications</b> ..... | <b>P4</b>  |
| 1. Pin assignment.....                    | <b>P4</b>  |
| a. TFT-LCD panel driving section.....     | <b>P4</b>  |
| b. Backlight driving section.....         | <b>P5</b>  |
| 2. Absolute maximum ratings.....          | <b>P5</b>  |
| 3. Electrical characteristics.....        | <b>P6</b>  |
| a. Typical operating conditions.....      | <b>P6</b>  |
| b. Current consumption.....               | <b>P6</b>  |
| c. Backlight driving conditions.....      | <b>P6</b>  |
| 4. AC Timing.....                         | <b>P7</b>  |
| a. Timing conditions.....                 | <b>P7</b>  |
| b. Timing diagram.....                    | <b>P7</b>  |
| <b>C. Optical specifications</b> .....    | <b>P8</b>  |
| <b>D. Reliability test items</b> .....    | <b>P10</b> |
| <b>E. Packing form</b> .....              | <b>P11</b> |

**Appendix:**

Fig.1 Outline dimension of TFT-LCD module. .... **P12**  
Fig.2 Sampling clock timing. .... **P13**  
Fig.3 Horizontal display timing range ..... **P14**  
Fig.4-(a) Horizontal timing. .... **P15**  
Fig.4-(b) Detail horizontal timing. .... **P16**  
Fig.5 Vertical shift clock timing. .... **P17**  
Fig.6-(a) Vertical timing (From up to down).. .... **P18**  
Fig.6-(b) Vertical timing (From down to up) ..... **P19**

Confidential

### A. Physical specifications

| NO. | Item                     | Specification          | Remark |
|-----|--------------------------|------------------------|--------|
| 1   | Display resolution (dot) | 480(W)×234(H)          |        |
| 2   | Active area (mm)         | 49.2(W)×38.142(H)      |        |
| 3   | Screen size (inch)       | 2.45(Diagonal)         |        |
| 4   | Dot pitch (mm)           | 0.1025(W)×0.163(H)     |        |
| 5   | Color configuration      | R. G. B. delta         |        |
| 6   | Overall dimension (mm)   | 59.9(W)×50.4(H)×4.5(D) | Note 1 |
| 7   | Weight (g)               | TBD                    |        |

Note 1: Refer to Fig. 1

Confidential

## B. Electrical specifications

| Pin No. | Symbol | I/O | Description   | Remark |
|---------|--------|-----|---|--------|
| 01      | GND    |     | Ground for logic circuit                                |        |
| 02      | VCC    |     | Supply voltage of logic control circuit for scan driver |        |
| 03      | VGL    | I   | Negative power for scan driver                          |        |
| 04      | VGH    | I   | Positive power for scan driver                          |        |
| 05      | STVR   | I/O | Vertical start pulse                                    |        |
| 06      | STVL   | I/O | Vertical start pulse                                    |        |
| 07      | CKV    | I   | Shift clock input for scan driver                       |        |
| 08      | U/D    | I   | Up/Down scan control input                              |        |
| 09      | OEV    | I   | Output enable input for scan driver                     |        |
| 10      | VCOM   | I   | Common electrode driving signal                         |        |
| 11      | VCOM   | I   | Common electrode driving signal                         |        |
| 12      | GLED1  |     | LED module 1 Cathode                                    |        |
| 13      | VLED1  |     | LED module 1 Anode                                      |        |
| 14      | VLED2  |     | LED module 2 Anode                                      |        |
| 15      | GLED2  |     | LED module 2 Cathode                                    |        |
| 16      | L/R    | I   | Left/Right scan control input                           |        |
| 17      | Q1H    | I   | Analog signal rotate input                              |        |
| 18      | OEH    | I   | Output enable input for data driver                     |        |
| 19      | STHL   | I/O | Start pulse for horizontal scan line                    |        |
| 20      | STHR   | I/O | Start pulse for horizontal scan line                    |        |
| 21      | CPH3   | I   | Sampling and shifting clock pulse for data driver       |        |
| 22      | CPH2   | I   | Sampling and shifting clock pulse for data driver       |        |
| 23      | CPH1   | I   | Sampling and shifting clock pulse for data driver       |        |
| 24      | DVDD   |     | Supply voltage of logic control for data driver         |        |
| 25      | DVSS   |     | Ground for logic circuit                                |        |
| 26      | VA     | I   | Alternated video signal input (Red)                     |        |
| 27      | VB     | I   | Alternated video signal input (Green)                   |        |
| 28      | VC     | I   | Alternated video signal input (Blue)                    |        |
| 29      | AVDD   |     | Supply voltage for analog circuit                       |        |
| 30      | AVSS   |     | Ground for analog circuit                               |        |

### 1. Pin assignment

#### a. TFT-LCD panel driving section

Note 1 : Selection of scanning mode

| Setting of scan control input |                 | IN/OUT state For start pulse |      |      |      | Scanning direction                       |
|-------------------------------|-----------------|------------------------------|------|------|------|--|
| U/D                           | L/R             | STVR                         | STVL | STHR | STHL |  |
| GND                           | V <sub>CC</sub> | OUT                          | IN   | OUT  | IN   | From up to down, and from left to right. |
| V <sub>CC</sub>               | GND             | IN                           | OUT  | IN   | OUT  | From down to up, and from right to left. |

|                 |                 |     |     |     |     |  |
|-----------------|-----------------|-----|-----|-----|-----|--|
| GND             | GND             | OUT | IN  | IN  | OUT | From up to down, and from right to left. |
| V <sub>CC</sub> | V <sub>CC</sub> | IN  | OUT | OUT | IN  | From down to up, and from left to right. |

IN: Input; OUT: Output.

Note 2 : Definition of scanning direction.

Refer to figure as below:

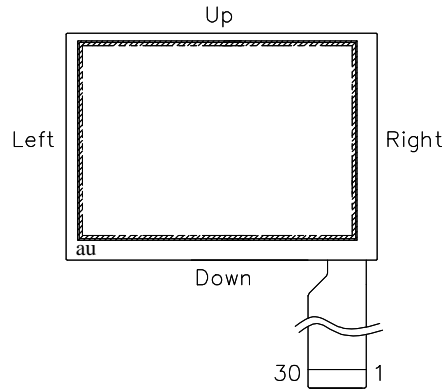

b. LED driving conditions(Refer to Fig.1)

| Parameter     | Symbol         | Min.    | Typ. | Max. | Unit | Remark   |
|---------------|----------------|---------|------|------|------|----------|
| LED current   |                |         | 20   |      | mA   |          |
| LED voltage   | V <sub>L</sub> |         | (15) |      | V    |          |
| LED Life Time | L <sub>L</sub> | (10000) |      |      | Hr   | Note 1,2 |

Note 1 : T<sub>a</sub>. = 25°C, I<sub>L</sub> = **20mA**

Note 2 : Brightness to be decreased to 50% of the initial value.

2. Absolute maximum ratings

| Item                  | Symbol                           | Condition           | Min. | Max.                  | Unit | Remark              |
|-----------------------|----------------------------------|---------------------|------|-----------------------|------|---------------------|
| Power voltage         | V <sub>CC</sub>                  | GND=0               | -0.3 | 7                     | V    |                     |
|                       | AV <sub>DD</sub>                 | AV <sub>SS</sub> =0 | -0.3 | 7                     | V    |                     |
|                       | V <sub>GH</sub>                  | GND=0               | -0.3 | 18                    | V    |                     |
|                       | V <sub>GL</sub>                  |                     | -18  | 0.3                   | V    |                     |
|                       | V <sub>GH</sub> -V <sub>GL</sub> |                     | -    | 36                    | V    |                     |
| Input signal voltage  | V <sub>i</sub>                   |                     | -0.3 | AV <sub>DD</sub> +0.3 | V    | Note 1              |
|                       | V <sub>I</sub>                   |                     | -0.3 | V <sub>CC</sub> +0.3  | V    | Note 2              |
|                       | V <sub>COM</sub>                 |                     | -2.9 | 5.2                   | V    |                     |
| Operating temperature | Topa                             |                     | 0    | 60                    | °C   | Ambient temperature |
| Storage temperature   | Tstg                             |                     | -25  | 80                    | °C   | Ambient temperature |

Note 1: VR, VG, VB

Note 2: STHL, STHR, Q1H,OEH,L/R,CPH1~CPH3, STVR, STVL,OEV,CKV,U/D.

### 3. Electrical characteristics

#### a. Typical operating conditions (GND=AVss=0V)

| Item                                      | Symbol     | Min.          | Typ.         | Max.          | Unit         | Remark                               |
|---|------------|---------------|--------------|---------------|--------------|--------------------------------------|
| Power supply                              | $V_{CC}$   | 3             | 5            | 5.2           | V            |                                      |
|   | $AV_{DD}$  | 4.5           | 5            | 5.2           | V            |                                      |
|   | $V_{GH}$   | 14.3          | 15           | 15.7          | V            |                                      |
|   | $V_{GLAC}$ | 3.5           | 5            | 7.5           | Vp-p         | AC component of $V_{GL}$ .<br>Note 1 |
|   | $V_{GL-H}$ | -10           | -9.5         | -9            | V            | High level of $V_{GL}$ .             |
| Video signal<br>Amplitude<br>(VR, VG, VB) | $V_{iA}$   | $AV_{SS}+0.4$ | -            | $AV_{DD}-0.4$ | V            | Note 2                               |
|   | $V_{iAC}$  | -             | 3            | -             | V            | AC component                         |
|   | $V_{iDC}$  | -             | $AV_{DD}/2$  | -             | V            | DC component                         |
| VCOM                                      | $V_{CAC}$  | 3.5           | 5            | 7.5           | Vp-p         | AC component, Note 3                 |
|   | $V_{CDC}$  | 0.95          | 1.1          | 1.25          | V            | DC component                         |
| Input<br>Signal<br>voltage                | H Level    | $V_{IH}$      | $0.8 V_{CC}$ | -             | $V_{CC}$     | Note 4                               |
|   | L Level    | $V_{IL}$      | 0            | -             | $0.2 V_{CC}$ |                                      |

Note 1: The same phase and amplitude with common electrode driving signal(VCOM).

Note 2: Refer to Fig.4-(a)

Note 3: The brightness of LCD panel could be adjusted by the adjustment of the AC component of VCOM.

Note 4: STHL, STHR, Q1H, OEH, L/R, CPH1~CPH3, STVR, STVL, OEV, CKV, U/D.

Note 5: Be sure to apply GND,  $V_{CC}$ ,  $V_{GL}$  to the LCD first, and then apply  $V_{GH}$ .

#### b. Current consumption (GND=AVss=0V)

| Parameter                | Symbol   | Condition       | Min. | Typ. | Max. | Unit    | Remark |
|--------------------------|----------|-----------------|------|------|------|---------|--------|
| Current<br>for<br>driver | $I_{GH}$ | $V_{GH}=15V$    | -    | 50   | 100  | $\mu A$ |        |
|                          | $I_{GL}$ | $V_{GL-H}=-10V$ | -    | -0.3 | -0.6 | mA      |        |
|                          | $I_{CC}$ | $V_{CC}=5V$     | -    | 1.5  | 4    | mA      |        |
|                          | $I_{DD}$ | $AV_{DD}=5V$    | -    | 5    | 10   | mA      |        |

#### c. Backlight driving conditions

| Parameter      | Symbol | Min.    | Typ. | Max. | Unit  | Remark    |
|----------------|--------|---------|------|------|-------|-----------|
| LED current    | $I_L$  |         | (20) |      | mArms |           |
| LED voltage    | $V_L$  |         | 15   |      | Vrms  | Note 1    |
| Backlight Life |        | (10000) |      |      | Hr    | Note 1, 2 |

Note 1 : Ta. = 25°C,  $I_L = 20mA$

The voltage ( $V_L$ ) is dependent on customer design for serial or parallel consideration of 8 LEDs.

Note 2 : Brightness to be decreased to 50% of the initial value.

### 4. AC Timing

#### a. Timing conditions

| Parameter | Symbol | Min. | Typ. | Max. | Unit. | Remark |
|-----------|--------|------|------|------|-------|--------|
|-----------|--------|------|------|------|-------|--------|



|                                 |                                     |      |             |             |             |           |
|---------------------------------|-------------------------------------|------|-------------|-------------|-------------|-----------|
| Rising time                     | $t_r$                               | -    | -           | 10          | ns          | Note 1    |
| Falling time                    | $t_f$                               | -    | -           | 10          | ns          | Note 1    |
| High and low level pulse width  | $t_{CPH}$                           | 299  | 308         | 319         | ns          | CPH1~CPH3 |
| CPH pulse duty                  | $t_{CWH}$                           | 40   | 50          | 60          | %           | CPH1~CPH3 |
| CPH pulse delay                 | $t_{C12}$<br>$t_{C23}$<br>$t_{C31}$ | 70   | $t_{CPH}/3$ | $t_{CPH}/2$ | ns          | CPH1~CPH3 |
| STH setup time                  | $t_{SUH}$                           | 35   | -           | -           | ns          | STHR,STHL |
| STH hold time                   | $t_{HDH}$                           | 35   | -           | -           | ns          | STHR,STHL |
| STH pulse width                 | $t_{STH}$                           | -    | 1           | -           | $t_{CPH}$   | STHR,STHL |
| STH period                      | $t_H$                               | 61.5 | 63.5        | 65.5        | $\mu s$     | STHR,STHL |
| OEH pulse width                 | $t_{OEH}$                           | -    | 3           | -           | $t_{CPH}$   | OEH       |
| Sample and hold disable time    | $t_{DIS1}$                          | -    | 28          | -           | $t_{CPH}$   |           |
| OEV pulse width                 | $t_{OEV}$                           | -    | 12          | -           | $t_{CPH}$   | OEV       |
| CKV pulse width                 | $t_{CKV}$                           | 16   | 28          | 40          | $t_{CPH}$   | CKV       |
| Clean enable time               | $t_{DIS2}$                          | -    | 10          | -           | $t_{CPH}$   |           |
| Horizontal display start        | $t_{SH}$                            | -    | 0           | -           | $t_{CPH}/3$ |           |
| Horizontal display timing range | $t_{DH}$                            | -    | 480         | -           | $t_{CPH}/3$ |           |
| STV setup time                  | $t_{SUV}$                           | 400  | -           | -           | ns          | STVL,STVR |
| STV hold time                   | $t_{HDV}$                           | 400  | -           | -           | ns          | STVL,STVR |
| STV pulse width                 | $t_{STV}$                           | -    | -           | 1           | $t_H$       | STVL,STVR |
| Horizontal lines per field      | $t_V$                               | 256  | 262         | 268         | $t_H$       | Note 2    |
| Vertical display start          | $t_{SV}$                            | -    | 3           | -           | $t_H$       |           |
| Vertical display timing range   | $t_{DV}$                            | -    | 234         | -           | $t_H$       |           |
| VCOM rising time                | $t_{rCOM}$                          | 2    | -           | 3           | $\mu s$     |           |
| VCOM falling time               | $t_{fCOM}$                          | 2    | -           | 3           | $\mu s$     |           |
| VCOM delay time                 | $t_{dCOM}$                          | -    | -           | 3           | $\mu s$     |           |
| RGB delay time                  | $t_{DRGB}$                          | -    | -           | 1           | $\mu s$     |           |

Note 1: For all of the logic signals.

Note 2: Please don't use odd horizontal lines to drive LCD panel for both odd and even fields simultaneously.

b. Timing diagram

Please refer to the attached drawings, from Fig.2 to Fig.6.

**C. Optical specification (Note 1, Note 2, Note 3)**

| Item               | Symbol | Condition                  | Min. | Typ. | Max. | Unit | Remark    |
|--------------------|--------|----------------------------|------|------|------|------|-----------|
| Response time      | Rise   | $\theta = 0^\circ$         | -    | 20   | 30   | ms   | Note 4, 6 |
|                    | Fall   |                            | Tf   | -    | 30   | 40   |           |
| Contrast ratio     | CR     | At optimized viewing angle | 100  | 150  | -    |      | Note 5, 6 |
| Viewing angle      | Top    | $CR \geq 10$               | 10   | -    | -    | deg. | Note 6, 7 |
|                    | Bottom |                            | 30   | -    | -    |      |           |
|                    | Left   |                            | 45   | -    | -    |      |           |
|                    | Right  |                            | 45   | -    | -    |      |           |
| Brightness         | $Y_L$  | $\theta = 0^\circ$         | 200  | 250  | -    | nit  | Note 8    |
| White chromaticity | X      | $\theta = 0^\circ$         | 0.26 | 0.31 | 0.36 |      | Note 8    |
|                    | y      |                            | 0.3  | 0.35 | 0.4  |      |           |

Note 1. Ambient temperature =25°C . and lamp current  $I_L = 2.7\text{mA}$ rms.

Note 2. To be measured in the dark room.

Note 3. To be measured at the center area of panel with a viewing cone of 1° by Topcon luminance meter BM-7, after 10 minutes operation.

Note 4. Definition of response time:

The output signals of photodetector are measured when the input signals are changed from “black” to “white”(falling time) and from “white” to “black”(rising time), respectively. The response time is defined as the time interval between the 10% and 90% of amplitudes. Refer to figure as below.

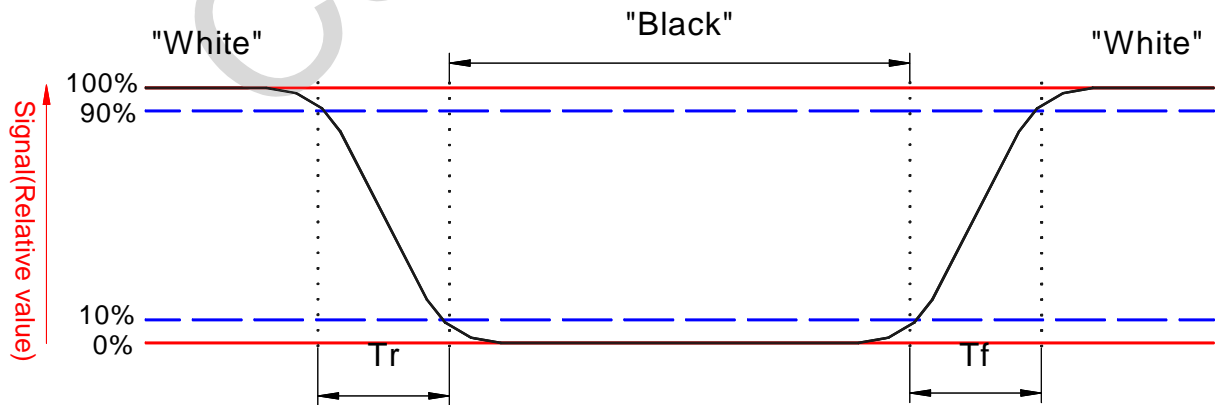

Note 5. Definition of contrast ratio:

Contrast ratio is calculated with the following formula.

$$\text{Contrast ratio (CR)} = \frac{\text{Photodetector output when LCD is at "White" state}}{\text{Photodetector output when LCD is at "Black" state}}$$

Note 6. White  $V_i = V_{i50} \overline{+} 1.5V$

Black  $V_i = V_{i50} \pm 2.0V$

“±” means that the analog input signal swings in phase with COM signal.

“ $\overline{+}$ ” means that the analog input signal swings out of phase with COM signal.

$V_{i50}$  : The analog input voltage when transmission is 50%

The 100% transmission is defined as the transmission of LCD panel when all the input terminals of module are electrically opened.

Note 7. Definition of viewing angle:

Refer to figure as below.

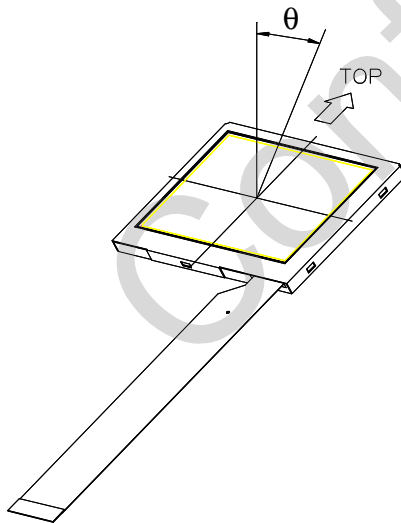

Note 8. Measured at the center area of the panel when all the input terminals of LCD panel are electrically opened.

**D. Reliability test items:**

| No. | Test items                         | Conditions   | Remark                            |
|-----|------------------------------------|--|-----------------------------------|
| 1   | High temperature storage           | Ta= 80°C                      240H   |                                   |
| 2   | Low temperature storage            | Ta= -25°C                      240H  |                                   |
| 3   | High temperature operation         | Ta= 60°C                      240H   |                                   |
| 4   | Low temperature operation          | Ta= 0°C                      240H  |                                   |
| 5   | High temperature and high humidity | Ta= 60°C . 95% RH            240H  | Operation                         |
| 6   | Heat shock                         | -25°C~80°C/50 cycle 2H/cycle   | Non-operation                     |
| 7   | Electrostatic discharge            | ±200V,200pF(0Ω), once for each terminal  | Non-operation                     |
| 8   | Vibration                          | Frequency range : 10~55Hz<br>Stoke : 1.5mm<br>Sweep : 10~55Hz~10Hz<br>2 hours for each direction of X,Y,Z<br>(6 hours for total) | JIS C7021,<br>A-10<br>condition A |
| 9   | Mechanical shock                   | 100G . 6ms, ±X,±Y,±Z<br>3 times for each direction   | JIS C7021,<br>A-7<br>condition C  |
| 10  | Vibration (with carton)            | Random vibration:<br>0.015G <sup>2</sup> /Hz from 5~200Hz<br>-6dB/Octave from 200~500Hz  | IEC 68-34                         |
| 11  | Drop (with carton)                 | Height: 80cm<br>1 corner, 3 edges, 6 surfaces  |                                   |

Note: Ta: Ambient temperature.

Confidential

### E.Packing form

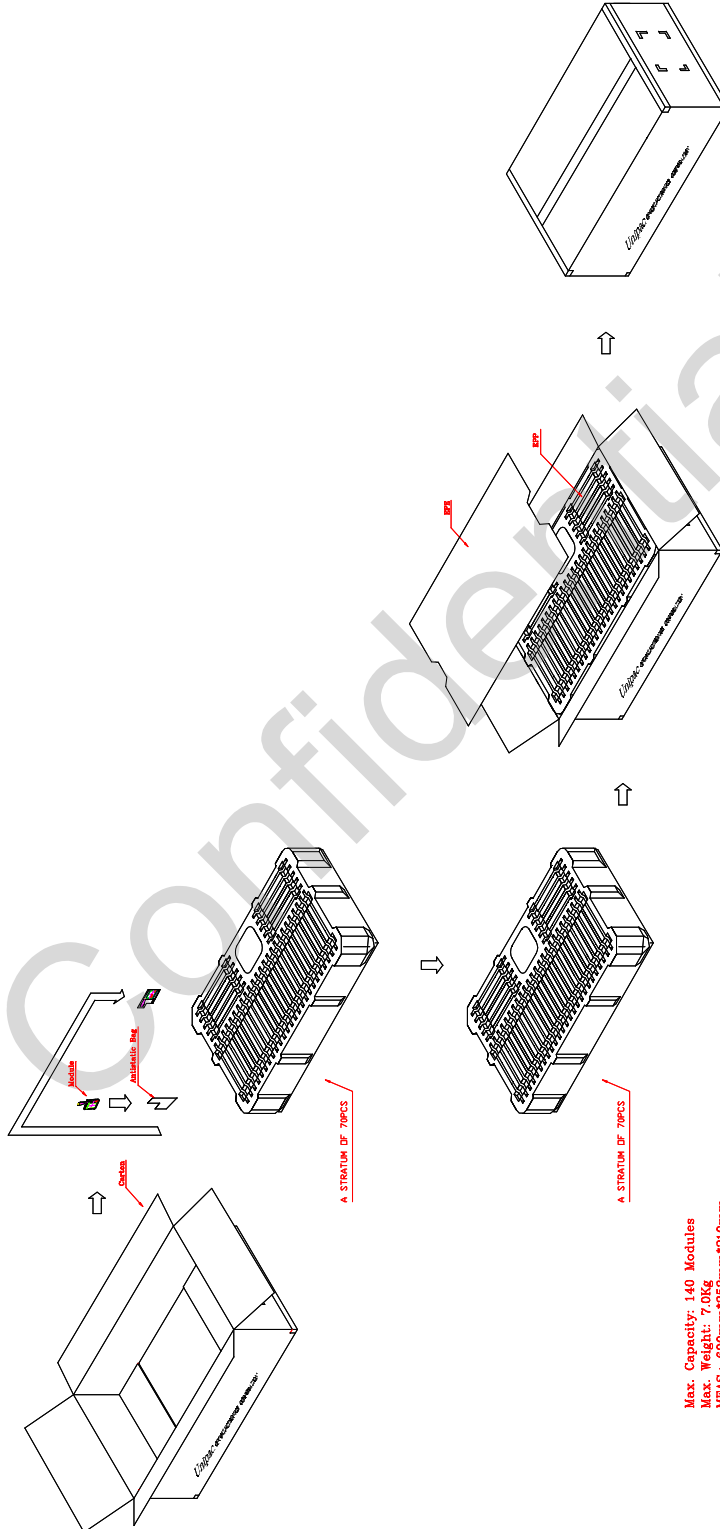

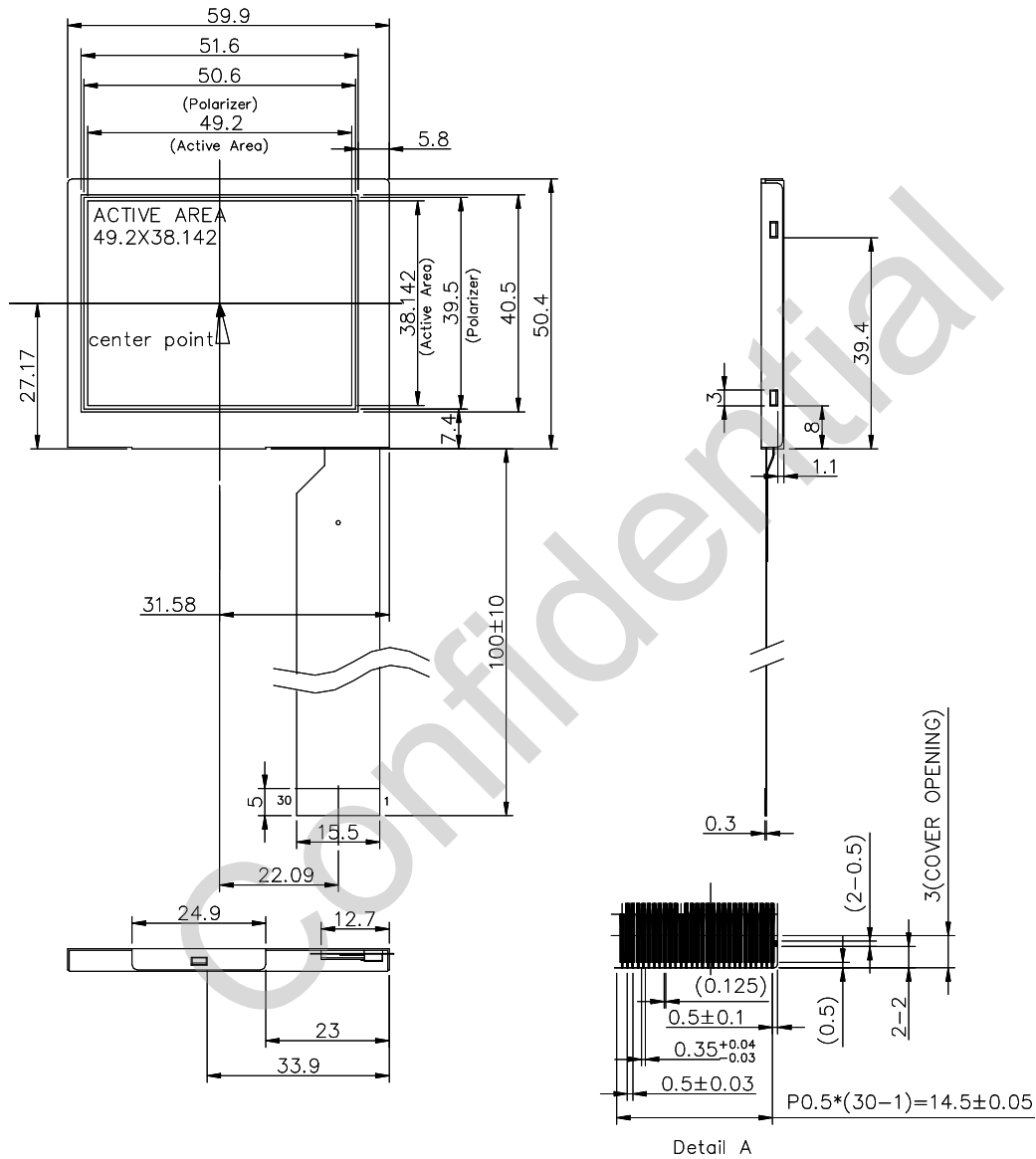

Fig.1 Outline dimension of TFT-LCD module

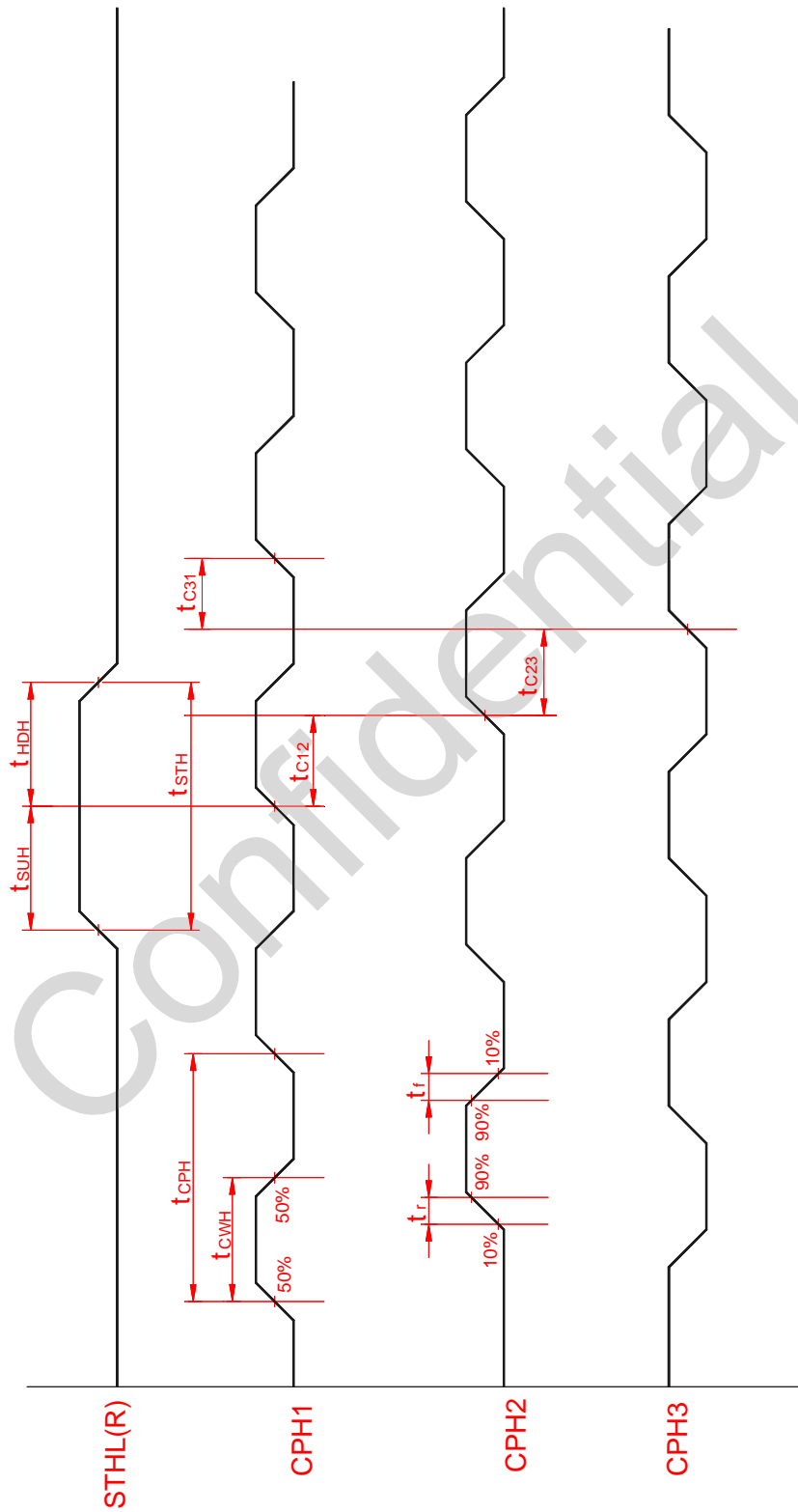

Fig.2 Sampling clock timing



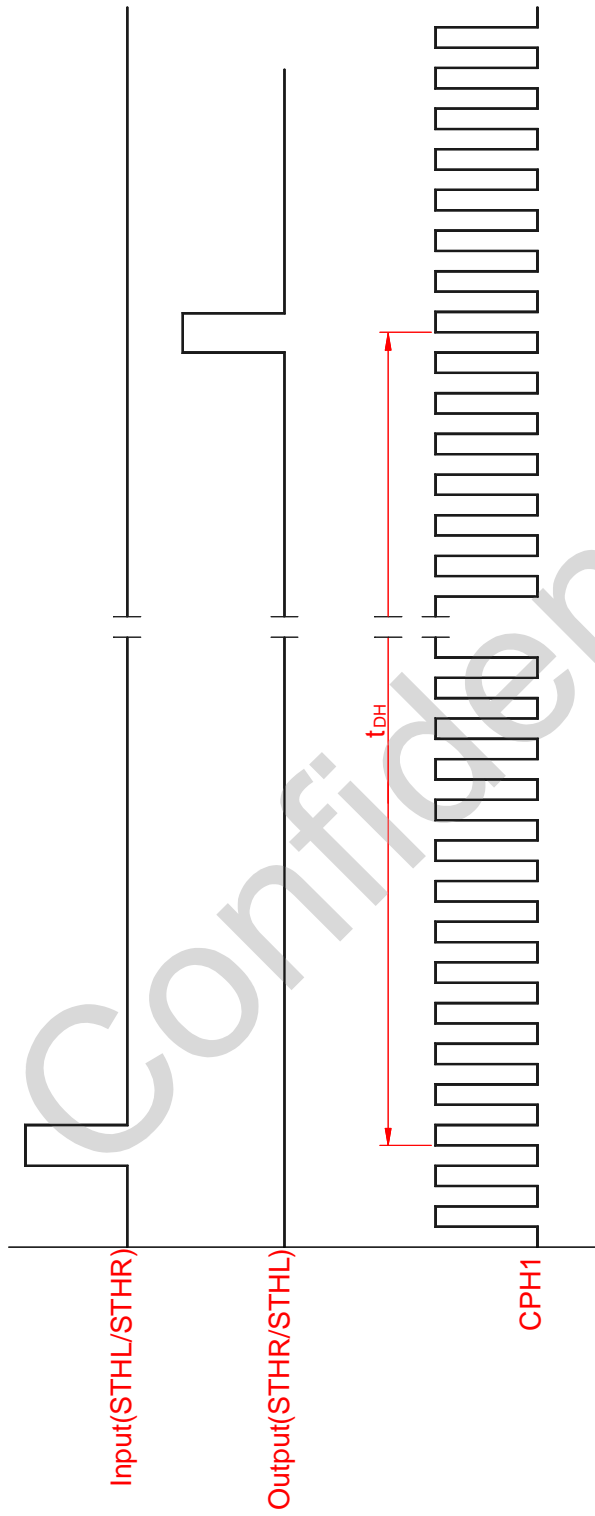

Fig.3 Horizontal display timing range

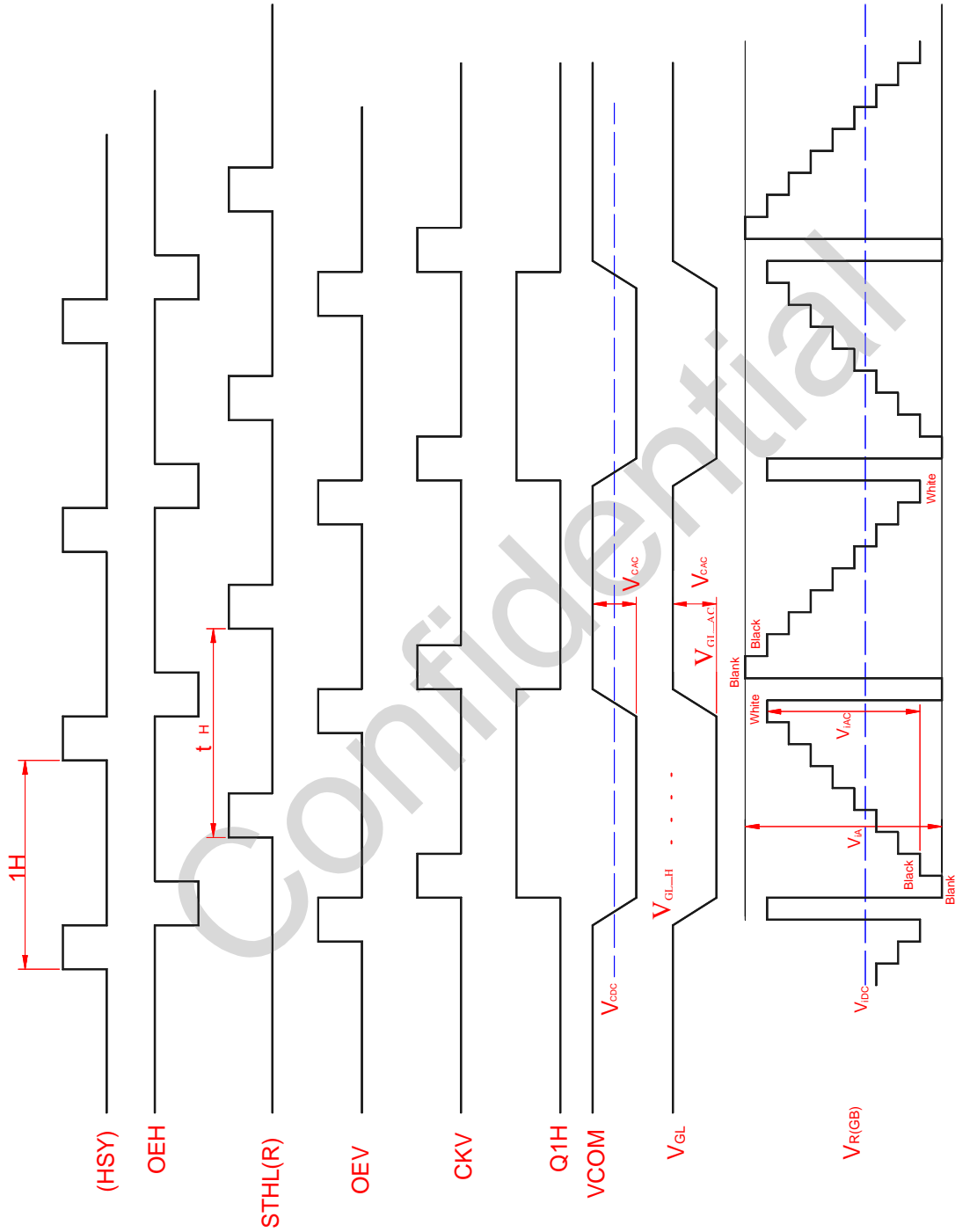

Fig.4(a) Horizontal timing

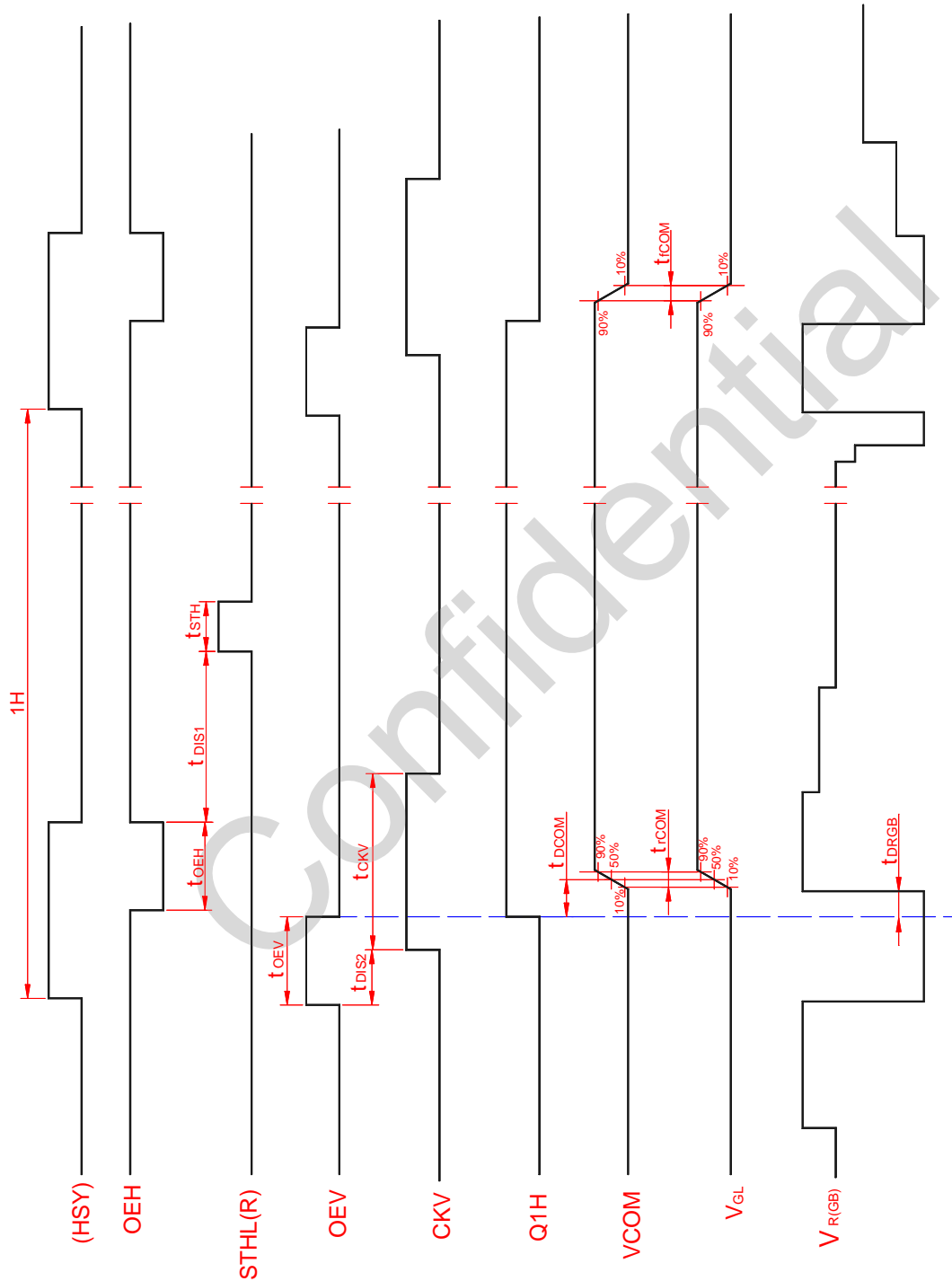

Fig.4-(b) Detail horizontal timing

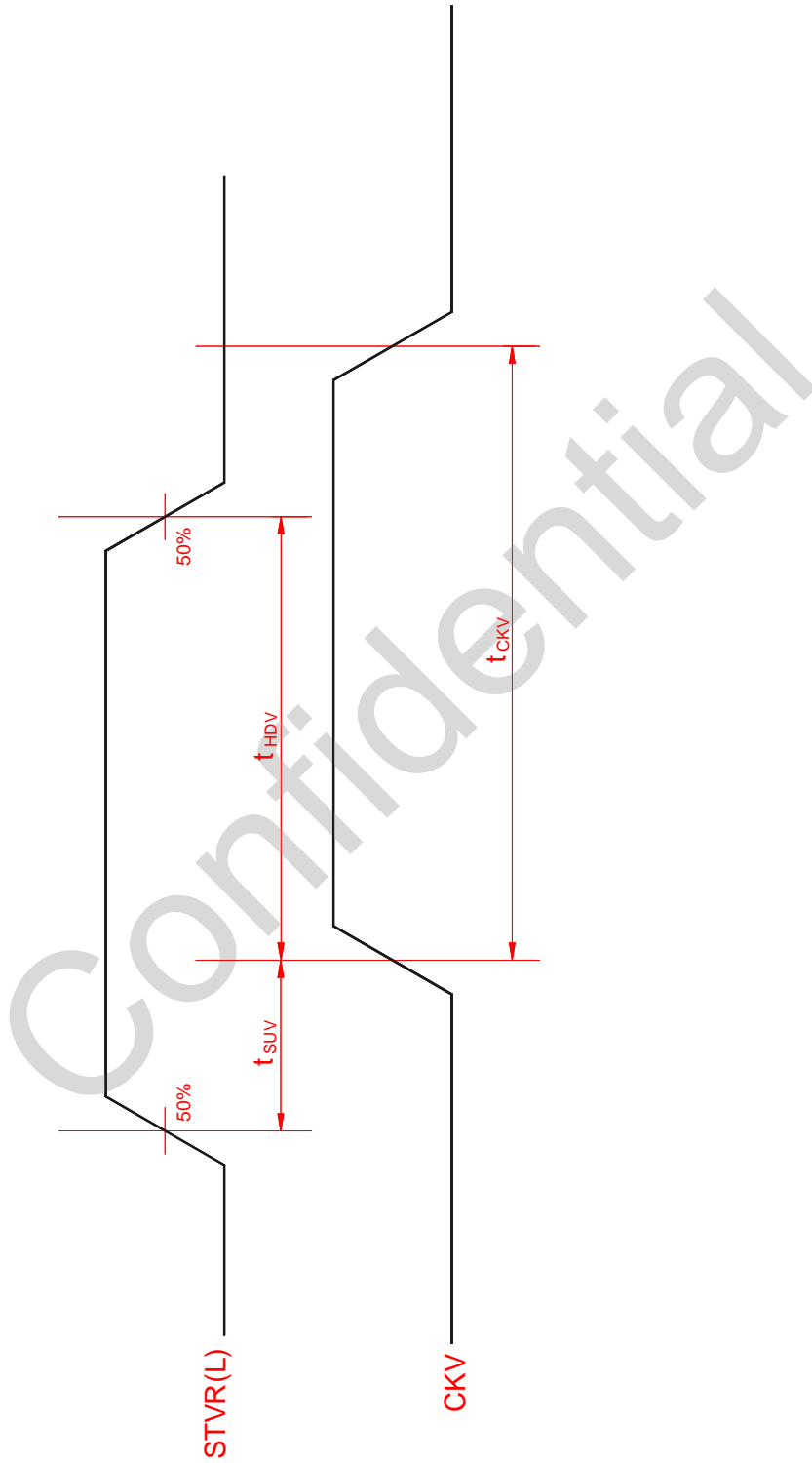

Fig.5 Vertical shift clock timing

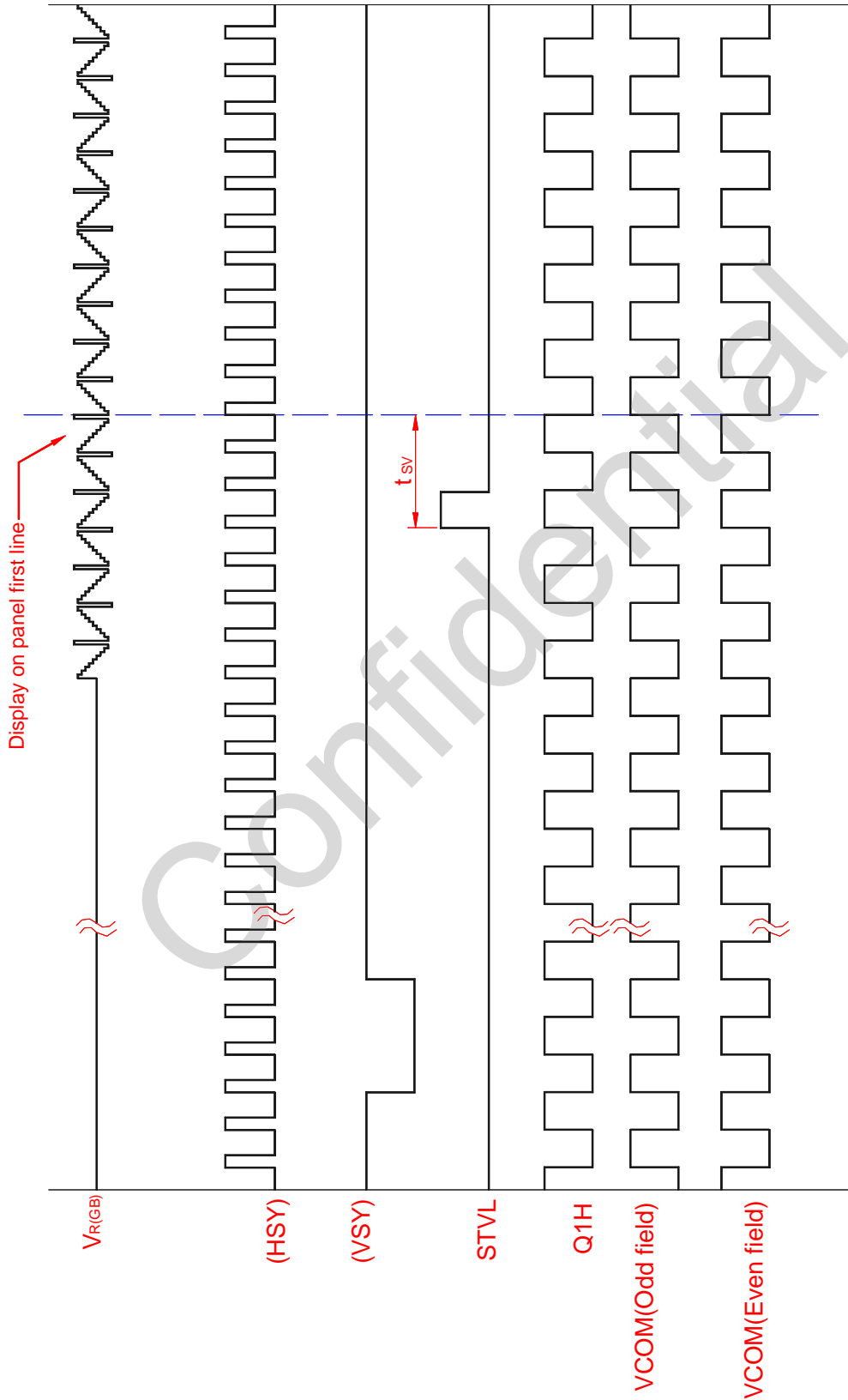

Fig.6-(a) Vertical timing (From up to down)

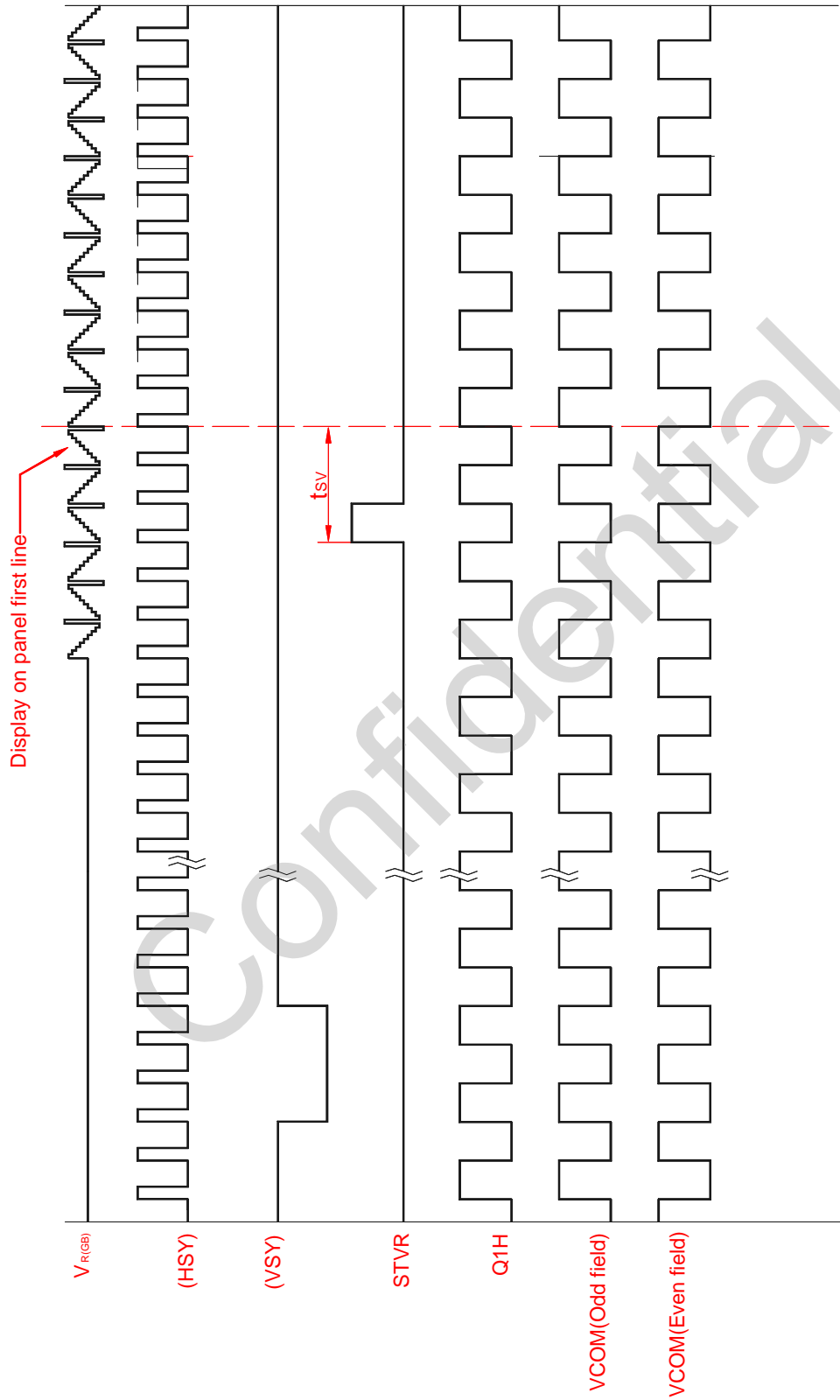

Fig.6-(b) Vertical timing (From down to up)